

Gas Spring Application Enquiry Form

www.jetpress.com

Please provide application details below - PLEASE USE BLOCK CAPITALS.

Contact Name:	Date Enquiry Received at JP :
Job Title:	JP Reference Number EN:
Company Name:	JP Originator Name:
Tel:	Fax:
Enquiry Reference:	Response Date Required by:

Please remember that the more information you can provide us with from the beginning the faster we can provide your gas spring solution!

● What is your Application?: _____
e.g. (machine guard, tool box cover)

● Describe the action you require from the gas spring on your application: _____

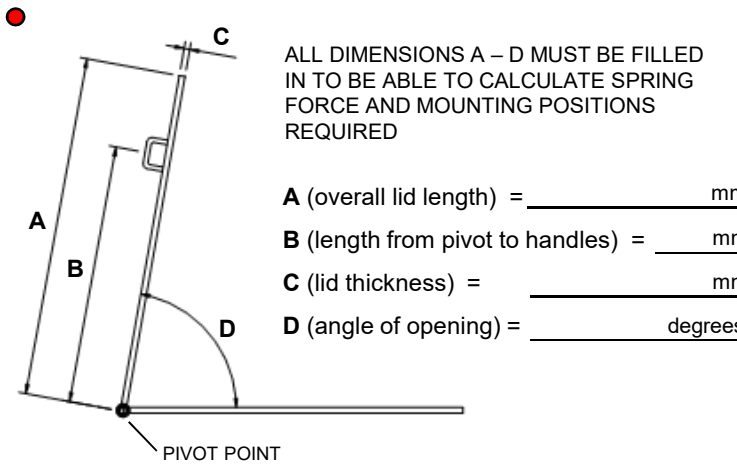

● Any restrictions on mounting space?: If Yes, identify on your sketch / drawing in the grid space allocated: _____

● What is the application lid weight?: _____ Kg

● Where is the Hinge pivot point on the lid? (please circle)
 e.g. top face of lid: or lower face of lid:

● Will the gas spring be subject to vibration whilst on the application? Y or N, If Y please describe _____

● Clearly State the Operating Temp Range: e.g. room temperature 21 °C Min : °C Max : °C

● Does the Operating Environment require – Standard Carbon Steel or Stainless Steel

● Number of operations / cycles per day:

● How Many Springs / Application?:

● Estimated Annual Quantity: Units

● Spring / Strut Type:

● Delivery / Batch Qty: Units

● Customer Part Number:

● Current Price (£)

● Current Supplier:

● Additional Comments

Where possible please provide your own drawings / sketches if available. All dimensions must be from the pivot point.

● Do you have any preferences as to when the gas spring takes over lifting? e.g. after 'x' degrees or instant lift _____

● Do you know your Centre of Gravity? (We need to know this in 2D (X & Y co-ordinates) from the pivot point. Please use grid below. If Yes XG = _____ mm, YG = _____ mm.

If not, please provide a detailed description of the lid shape. e.g. 2" flat steel plate, no additional features, no holes in material and no voids _____

